



**AL808 Series
Temperature & process
controller**

Instruction Manual

Contents

1. General Description.....	1
2. Features.....	1
3. Model Code.....	2
4. Installation.....	3
5. Wiring.....	4
6. Operator Interface.....	7
7. Basic Operations.....	8
8. Sensor Break.....	11
9. PID Self-Tuning.....	11
10. Configuration.....	13
11. Linear Input.....	17
12. Programmer/Controller.....	19
13. AL809 Valve Positioning Controller.....	23
Technical Data.....	24
Measurement Range	24

This Manual is applicable to V6.40 and above

1. General Description

The AL808 series controller is indented for industrial temperature and process control applications. Model 808 are digital temperature controllers. The 809 are valve positioning controllers.

Parameters and configuration values are set by use of the front panel keys. The PAR button selects the parameter and the up and down arrows are used to alter their value. The controller can be switched directly from automatic operation to manual by means of A/M button.

Without change of the hardware the main process variable input of the instrument can be configured to suit various thermocouples and resistance thermometers,(Pt100). Recalibration is not necessary for this procedure. Signals up to 50mV can be accommodated by using input adapters in the linear input option. Linearisation is scaleable within the display range of -999 to 9999, with tenths display resolution.

2. Features

The AL808/AL809 is a versatile, high stability temperature or process controller, with self-tuning, in 1/4 and 1/8 DIN sizes. It has a modular hardware construction with the option of two control outputs, two alarm relays and a communications module. Two digital input are included as standard. The hardware is configurable for heating, cooling or alarm.

Precise control

An advanced PID control algorithm gives stable straight-line control of the process. A on-shot tuner is provided to set up the initial PID values and to calculate the overshoot inhibition parameters. On electrically heated loads, power feedback is used to stabilise the output power and hence the controlled temperature against supply voltage fluctuations.

Dedicated cooling algorithms ensure optimum control of fan, water and oil cooled system.

Universal Input

A universal input circuit with a advanced analogue to digital convertor samples the input at 8Hz and continuously corrects it for drift. This gives high stability and rapid response to process changes. High noise immunity is achieved by rejection of 50/60Hz pick-up and other sources of noise. Sensor diagnostics are also provided. The input will accept all standard thermocouples, the Pt100 resistance thermometer and linear millivolts, milliamps or DC volts.

Input filtering from OFF to 999.9 seconds is included.

Easy to Use

A simple LED display provides a bright, clear display of the process value and setpoint. Tactile pushbuttons ensure positive operation. Access to other parameter is simple and easy to understand and can be customised to present only those parameters that need to be viewed or adjusted. All other parameters are lock away under password protection.

Alarms

Up to four process alarms can be combined onto a single output. They can be full scale high or low deviation form setpoint, rate of change or load failure alarms. Alarms messages are flashed on the main display. alarms can be configured as latching or non-latching and also as blocking type alarms which means that they will become active only after they have first entered a safe state.

Digital Communications

For communications with a host computer system the instrument can be fitted with either an EIA485 or EIA232 digital interface. This enables the automatic recording of measured values on a printer.

3. Model Code

Check the model code from the following list to determine if the product delivered is as desired.

The hardware model definition for the AL808 is as following:

3.1 Explanation of the model code

Alphanumeric character to represent the function or type is applied to the

[Example]

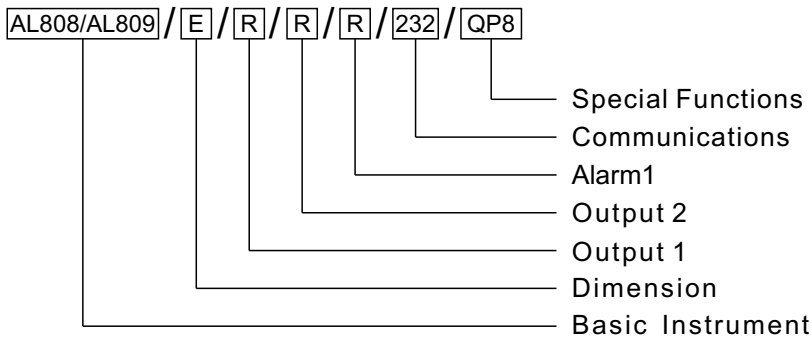

Basic Instrument:

AL808	Temperature controller
AL809	Valve positioning controller

Special Functions:

0	NONE
QP4	4-segment program
QP8	8-segment program
QP16	16-segment program
QP32	32-segment program

Dimensions(W×H×D):

N/A	96×96×100
D	48×96×100
E	96×48×100
M	72×72×100
S	48×48×100
A	160×80×100
B	80×160×100

Communications:

0	NONE
232	RS232 (3 lines)
485	RS485 (2 lines)

Output 1 & Output 2:

0	NONE
R	Relay, 3A/250V AC
L	Logic, 20V/10mA, to drive SSR
T	TRIAC
D	0~10 mA, 4~20 mA, 0~20 mA, 0~5 V, 1~5 V, and 0~10 V

Alarm1:

0	NONE
R	Relay, 3A/250V AC

4. Installation

This instrument is intended for permanent installation, for indoor use only, and enclosed in an electrical panel. Select a location which is subject to minimum vibrations and the ambient temperature is within 0 and 55 °C(32-131°F).

This instrument can be mounted on a panel up to 15mm thick.

4.1 Outline Dimensions

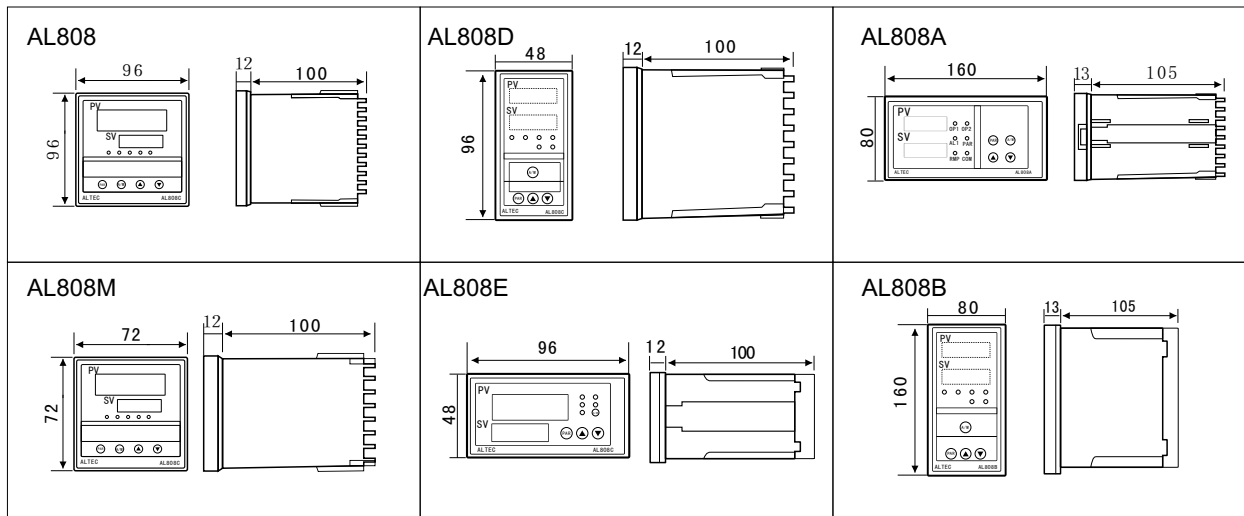

4.2 Panel Mounting the Controller

1. Prepare a square cut-out in the mounting panel to the size shown below. If a number of controllers are to be mounted in the same panel they should be spaced as shown.
2. Insert the controller through the cut-out.
3. Catch the mounting bracket to the holes top and bottom of the case, and screw to fix.

Panel cutout drawings

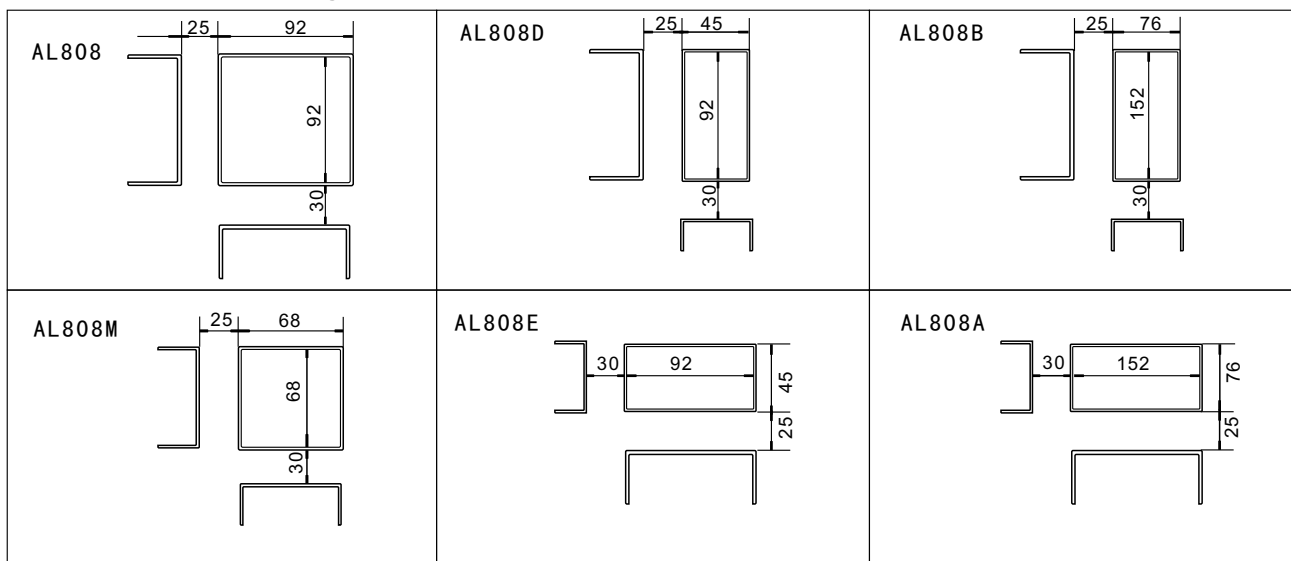

5. Wiring

The terminals at the rear of the instruments are numbered different. The detail terminal allocation is shown in the following figures.

Notice

1. Connections between thermocouple and controller must be made with appropriate compensating cable.
2. For RTD input, the length and gauge of all three wires must be equal.
3. Input wire shall be away from the instrument's power wire and load wire, so as to avoid sources of noise.
4. The input to the controller must be between -10mV to 50mV, Voltage signal which **exceed** this range must be attenuated with an appropriately sized input adapter. Current signals are converted to the -10 to 50mV range with a shunt input adapter.
5. For logic or analogue output, remember not to connect the output terminals to power wire, otherwise, the instrument will be burnt.

5.1 Terminal Layout

Al808 type (96 mm×96 mm)

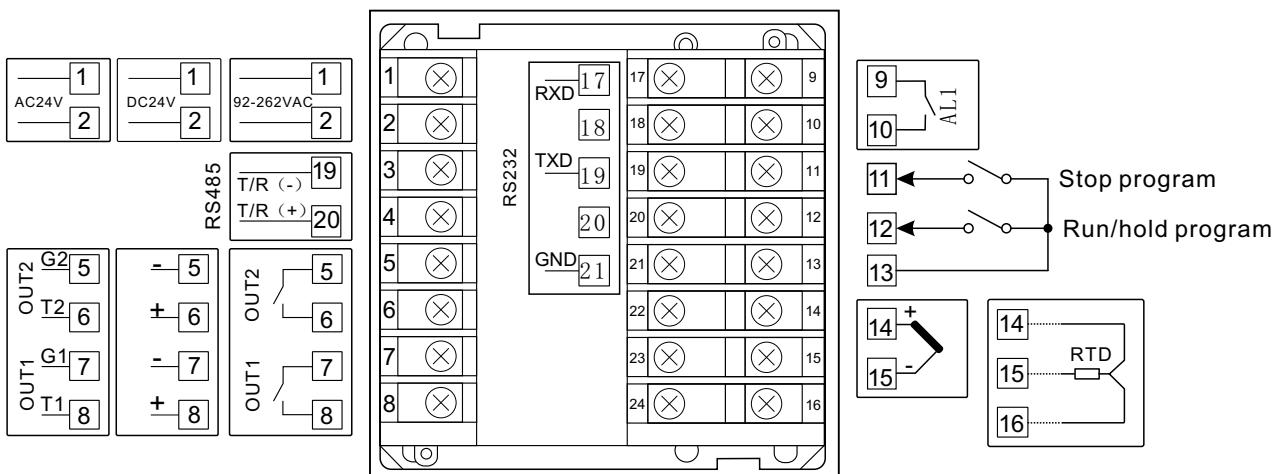

AL808D & AL808E type (96 × 48 mm, 48 × 96 mm)

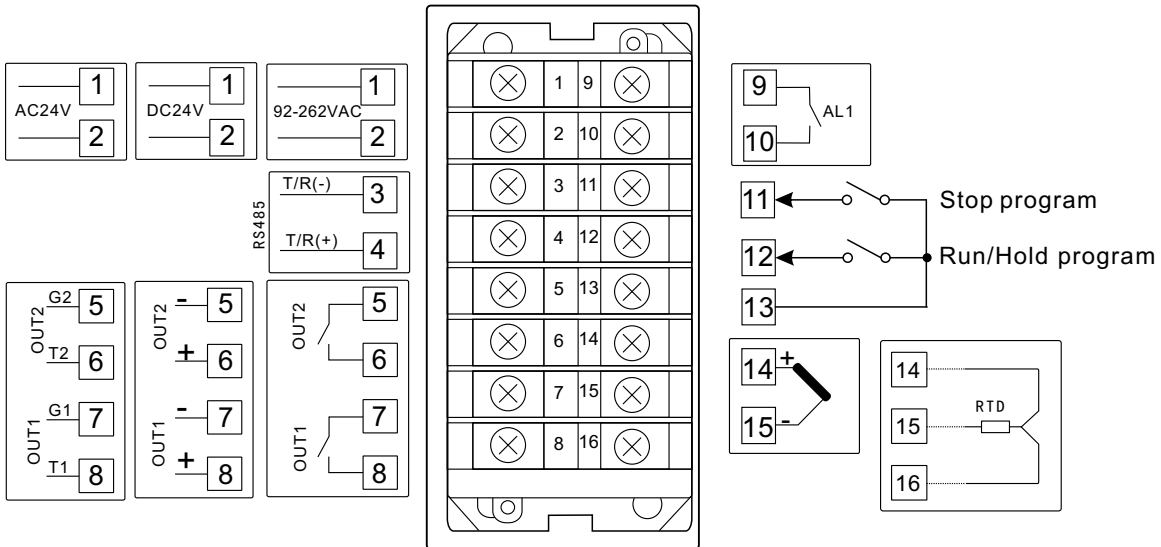

AL808M type (72 × 72 mm)

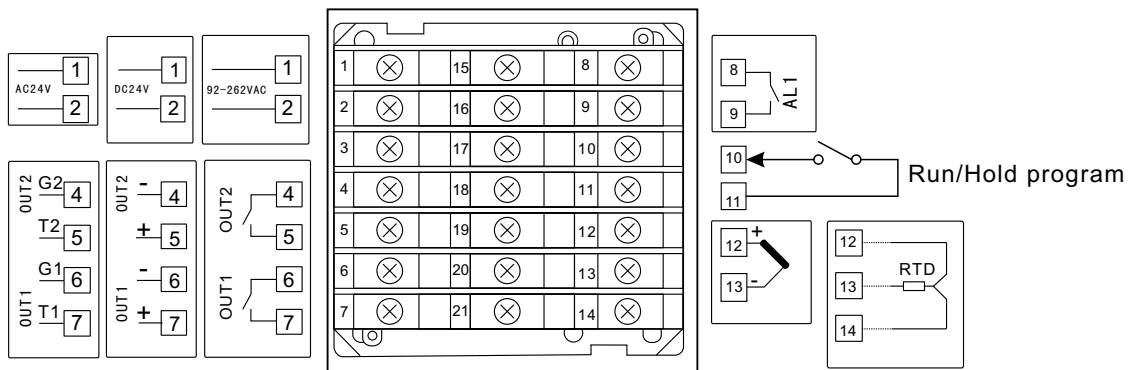

AL808A & AL808B type (160 × 80 mm, 80 × 160 mm)

K1: Stop program
K2: Run/Hold program

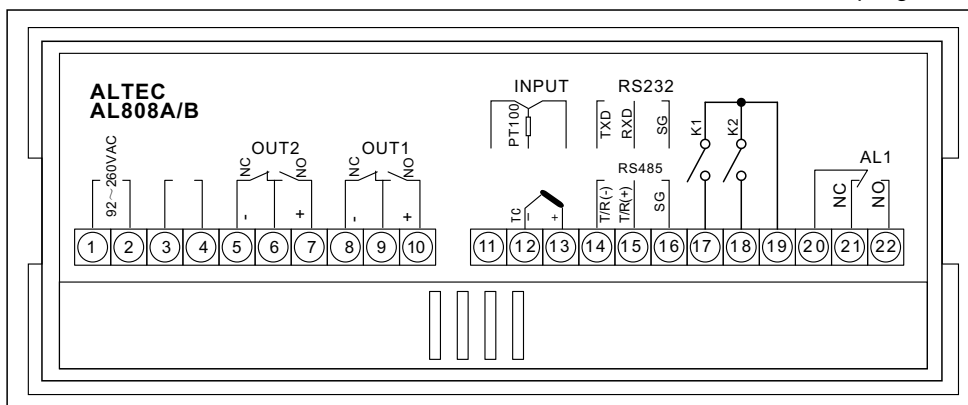

5.2 AL808 Triac Output

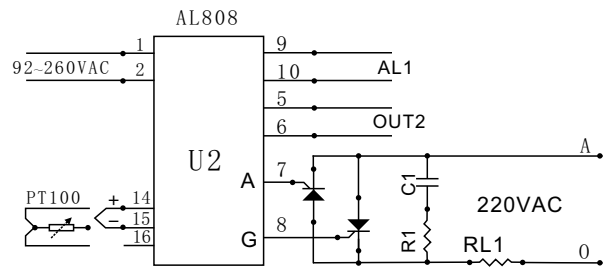
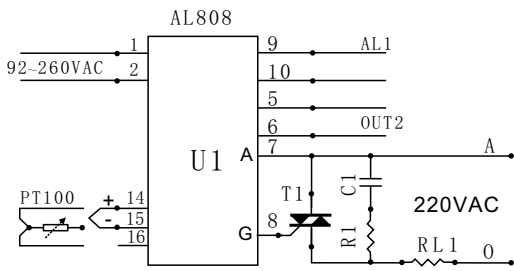

5.3 AL808 three-phase SCR output (panel size: 96×96)

5.3.1 AL808 three-phase SCR output

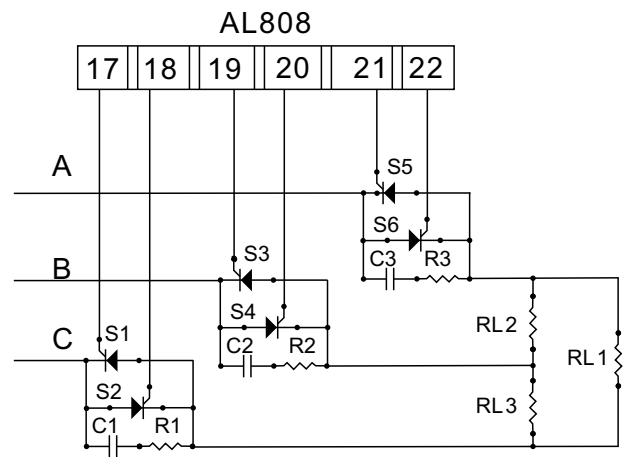
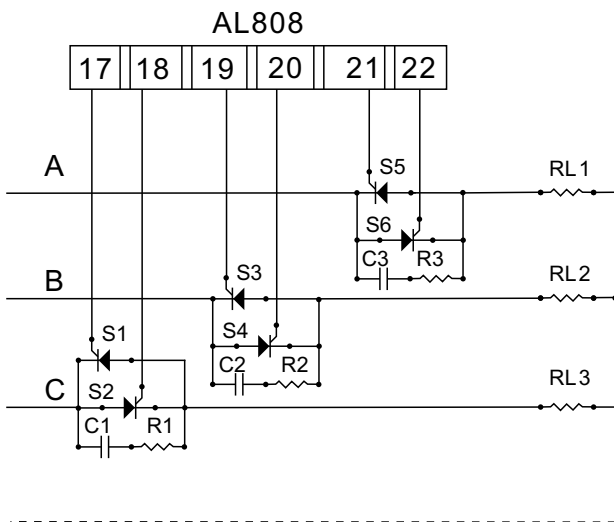

5.3.2 AL808 three-phase Triac Output

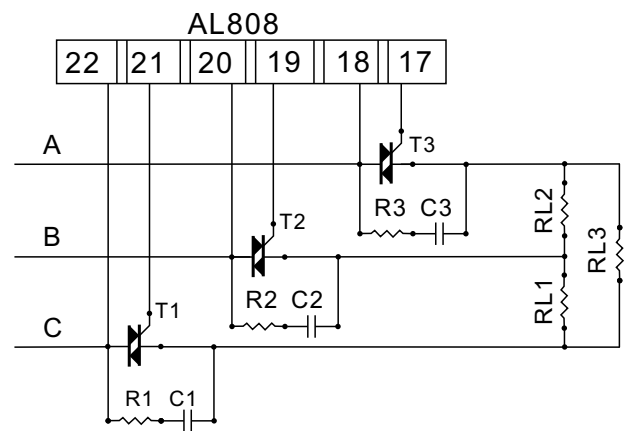
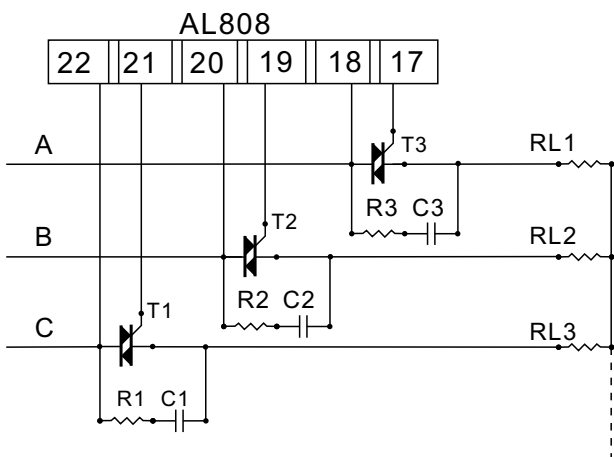

6. Operator Interface

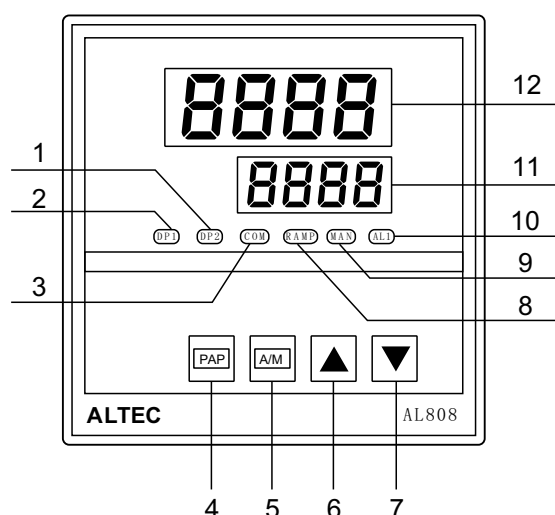

- 1) Output2 indicator(OP2)
- 2) Output1 indicator(OP1)
- 3) Communication indicator(COM)
- 4) Parameter scroll pushbutton(PAR)
- 5) Auto/manual operation selection pushbutton(A/M)
- 6) Raise parameter value pushbutton(▲)
- 7) Lower parameter value pushbutton(▼)
- 8) program running indicator(RAMP)
- 9) Manual operating mode indicator(MAN)
- 10) Alarm1 indicator (Red)
- 11) Measured Temperature or Process Value(PV)
- 12) Required Temperature or setpoint(SV)

6.1 Display

There are two LED display indicate the operating parameters.

The **upper display**(green) indicates the measured value when in base condition. On selecting a parameter, the appropriate parameter abbreviation appears.

The **lower display**(red) indicates the setpoint when in the automatic mode. On selecting a parameter, the appropriate parameter value appears here.

When the instrument is powered on, the upper display indicates the basic models of the instrument, and the lower display indicates the software version of the instrument (for customized instruments, customers shall pay special attention to the software version to facilitate purchase in the future).

3 seconds later, the upper display will indicate measured values (PV), and the lower display will indicate set values (SV), or, when the instrument is under manual control (indicator 'MAN' is illuminated), the lower display will indicate the output power.

Both the LED indicators 'OP1' and 'OP2', indicate the state of the relevant output. The LED is illuminated when the output is 'on'.

If output 1 is fitted with a DC output, the intensity of the indicator varies with the magnitude of the output level. If the DC output is configured as 4 to 20mA the LED glows dimly even with an output level of 0%.

If output 2 is configured as an alarm output, the LED is illuminated when the alarm is active.

The LED indicator 'COM' flashes when the controller is in active communication with a host computer via the digital communications board(only if option 'digital communications board' has been installed).

The LED indicator 'RAMP' is illuminated when the setpoint is ramping towards the target setpoint (only if ramp-to-setpoint has been configured).

The LED indicator 'MAN' indicates **manual** operating mode, the indicator flashes if sensor break is

detected.

6.2 Operating Buttons

The defined parameter list is scrolled through in sequence using the **parameter pushbutton ('PAR')**. By pressing the button, the abbreviation of the next parameter is shown in the upper display. The value associated with this parameter is shown in the lower display. If no change is made in the following 16 seconds by pressing the PAR button, the display returns to the base condition. This time-out can be overridden by holding down the PAR button.

In alarm condition, a latched alarm is acknowledged by one press of the PAR button.

With the **Lower pushbutton**, the value of the displayed parameter is decreased (insofar as modification is permitted). The speed increases as long as the button is depressed.

With the **Raise pushbutton**, the value of the displayed parameter is increased (insofar as modification is permitted). The speed increases as long as the button is depressed.

With the **Auto/manual button ('A/M')**, the controller is switched from automatic operating mode to the manual mode. Depressing the button again returns the controller to automatic. The changeover is bumpless, the output level at the time of the changeover is transferred into the required operating mode. If the instrument is configured as an ON/OFF controller, the output level can only assume one of two values (0 or 100%). This button can be locked out in the configuration level, so that the instrument remains in the operating mode chosen before lockout. If the instrument cannot be

7. Basic Operations

7.1 Operating Modes

The controller can function in three different operating modes. In **automatic** or closed loop, the output of the controller is determined by the control algorithm. In the base condition, the process value and the setpoint appear on the LED display. The setpoint is modified by the ▲ and ▼ buttons. Changeover to manual is through the A/M button (if not locked out).

If the controller is switched to **manual** operating mode, the output level is operator-adjustable by means of the ▲ and ▼ buttons, control is then open-loop. In the base condition, the process value and the output level appear on the LED display. Illumination of the '**MAN**' indicator indicates **manual** operating mode.

In the manual mode, the percent power output is the parameter modified by this same procedure; its upper limit may have a ceiling placed on it by **HPL** (high power limit).

If sensor break is detected at the input of the instrument, an output level defined by the operator, (parameter S_{nbP}) is given on output. The control loop is open here as well. For heat control, the parameter S_{nbP} can be adjusted in range 0 to 100%, and for heat/cool control, in the range -99.9 to 100%.

A sensor break or input error occurs if the input circuit is open or the measured value on the input over- or underranges the linearisation span of the instrument. If the input circuit is open, or the measured value is overrange, the annunciation S_{nbP} is shown on the upper display. If the

measurement is underrange (e.g. reversed, incorrect thermocouple connection) the annunciation *ur* appears. In both cases, the flashing M beacon indicates that the output level is set at the value determined by the parameter *5nbP*.

7.2 Control Algorithm

Four different control algorithms can be configured:

- **ON/OFF controller** (heat only, no cool):

The instrument functions as a two-state controller with a controller switch point (heat output only).

PrdP becomes hysteresis if *LtrL* is configured as *On.Off*

- **PID controller** with immediate setpoint modification

The PID control algorithm includes self-tuning and special parameters for optimal start-up.

The setpoint can be freely modified between the configured limits (see parameter list), when the actual value is indicated in the upper display and the setpoint in the lower display.

- **PID controller** with **ramped setpoint** modification

For setpoint modification, an adjustable ramp to setpoint can be entered which prevents excessive thermal shock to sensitive loads.

During ramp to setpoint the process value is indicated in the upper display and the target setpoint in the lower. The R beacon is illuminated until the target setpoint has been reached. In order to view the instantaneous setpoint, the PAR button must be pressed once. The Ramp beacon flashes during display of the instantaneous setpoint.

With the HB parameter the maximum allowable deviation between the process value and the instantaneous setpoint can be defined. The value is directly entered in LED display units. If the deviation exceeds HB ramping is halted and the Ramp beacon flashes. The function of holdback is further explained below.

If the ramp rate or the target setpoint is modified during ramp to setpoint this modification directly affects active ramping.

7.3 Modifying the Adjustable Parameter

When the instrument displaying the measured value and the setpoint, depressing PAR pushbutton (about 3 seconds) reveals the first parameter. Depressing PAR once again shows the next enabled parameter and its current value on the display. The parameter value can either be modified with the lower and raise pushbuttons, or left unmodified. Pressing PAR again displays the next parameter and its current value and so on.

Parameter List

S.N.	Mnemonic	Parameter	Adjustable range	Comments
1	<i>CF</i>	Display units	Display only	Celsius or Fahrenheit (Read only)
2	<i>Prog</i>	Programmer/controller status (display & selection)	<i>idLE</i> <i>run</i> <i>HalD</i>	Closed loop control Program running Program halted
3	<i>SP</i>	Setpoint in closed loop	<i>SPH--SPL</i>	
4	<i>tunE</i>	Active self-tune	<i>OFF</i> <i>on</i>	Stop PID self-tune Start PID self-tune
5	<i>AL1</i>	Alarm 1	Measurement range	
6	<i>AL2</i>	Alarm 2	Measurement range	
7	<i>HYS1</i>	AL1 Hysteresis	1~300°C	*Optional
8	<i>HYS2</i>	AL2 Hysteresis	1~300°C	*Optional
9	<i>ProP</i>	Proportional band	1~2000°C	Becomes hysteresis if <i>Ctrl</i> is configured as <i>On,OF</i>
10	<i>Int.t</i>	Integral time constant	OFF and 1 to 8000 s	Disappears if <i>Ctrl</i> = <i>On,OF</i>
11	<i>dEr.t</i>	Derivative time constant	OFF and 1 to 999 s	Disappears if <i>Ctrl</i> = <i>On, OF</i>
12	<i>rEL.c</i>	Relative cool gain	0.1 to 10.0	Appears during heat/cool
13	<i>db</i>	Dead band	0.1 to 10.0	Appears during heat/cool
14	<i>H.c.t</i>	Heat cycle time	0.1 to 240.0s	Disappears if <i>Ctrl</i> = <i>On, OF</i>
15	<i>c.c.t</i>	Cool cycle time	0.1 to 240.0s	Appears during heat/cool
16	<i>Loc</i>	Set data lock	0 to 9999	

1. Proportional Band(*ProP*)

This is the band of error within which the power output is proportional to the error. Error values outside this band give 100% or 0% power output.

If the proportional band is too narrow it will give control resembling on/off control with continuous oscillation. Wide proportional bands give stable but sluggish control with an offset in the steady-state condition.

2. Integral Time(*Int.t*)

This term provides automatic compensation for long term control offsets. It is the time taken for the output to change by one proportional band width for a constant error equal to the proportional band. Typically this must be set to a value longer than the response time of the process being controlled.

3. Derivative Time(*dEr.t*)

This term provides anticipation and fast recovery from disturbances. It can be taken as the 'look ahead' period of the controller. It is typically set to a time approximately one sixth of the integral time.

4. Relative cool gain(*rEL.c*)

This parameter (*rEL.c*) indicates the relationship between the heating and cooling performance of the controlled equipment. By this means, a special proportional band is defined for the cool channel, which is calculated from the value for the heat channel and the factor set in

$rEL.c$. The parameter is set according to the ratio: $rEL.c = \text{heat performance} : \text{cool performance}$

Therefore the heating/cooling effectiveness values of the controlled equipment must be known or deduced. The parameter must be correctly set without fail before activating self-tuning, as tuning relies on this value of calculating the control parameters.

5. Cycle time ($Hc.t$, $cc.t$)

The cycle time of the switching outputs ($Hc.t$ and $cc.t$) should be set high value (e.g. 20 seconds) if contactors are used, and to low values (e.g. 1 second for logic output) if thyristors are used.

8. Sensor Break

If a **sensor break** is detected at the input of the instrument, one of the output levels defined by the user ($SnbP$ Parameter) is given on the output. The control loop is therefore open. The $SnbP$ parameter can be adjusted for heat control in the range 0 to 100% and for heat/cool control in the range -99.9 to 100%.

A sensor break and likewise an input error occurs when the input is open circuit or the measured value at the input over or underranges the linearisation span of the instrument. If the input is open circuit or the measured value is overrange, the annunciation $SnbP$ appears on the upper display. In an underrange condition (reversed polarity or wrong thermocouple connection) the annunciation ur appears. In both cases, the flashing M beacon indicates that the output level is set at the value defined by the parameter $SnbP$.

If, on the configuration level, a change in operating mode has been authorised to **manual**, the operator can directly modify the output level with the raise or lower buttons. By pressing the A/M button once, the operator can enter definitively manual mode. This operating mode can only be quitted after the sensor break condition has been corrected and by pressing the A/M button again. If the manual operating mode is not abandoned, the output level cannot be modified by the operator if a sensor break has occurred.

9. PID Self-Tuning

9.1 PID Self-Tuning--General

AL808 and AL809 controllers have in-built self-tuning as a standard feature, which can be activated by the user on demand. According to a special procedure, the instrument examines the process reaction curve and calculates by means of a complex computer algorithm the optimum control parameter, using the data measured during the procedure. The parameters thereby obtained after successful tuning are automatically set into the instrument. Control parameters can be adapted in this way at any time for new or modified process reaction curves. It is not necessary to pre-adjust the control parameters before tuning, this is an important advantage over customary procedure.

Note: The adjustment procedures used here apply thermal shocks; in sensitive systems damage can occur. The adjustment procedure relies on correct configuration of the controller for the process and can only work correctly if these pre-conditions are met.

A self-tune procedure from setpoint is performed if, on activating self-tuning, the measured value and the setpoint are approximately equal, e.g. when the process reaction curve has converged. This procedure can be used for post-tuning the curve in the finalised control set-up.

Self-tuning calculates the following control parameters:

- $ProP$ Proportional band

- *Int.t* Integral time constant
- *Der.t* Derivative time constant

9.2 Self-tuning--Operation

In order to achieve good control results, the actual value should be broadly stable before the start. The algorithm functions even if the actual value is unstable but it evaluates this change as part of the process reaction curve.

During the course of the operation, the annunciation *tunE* flashes in the lower display. During this periods, do not change any of the instrument parameters. The tuning operation is finished when the annunciation *tunE* no longer flashes in the lower display. The user can abort self-tuning at any time by setting the parameter *tunE* to *OFF*.

9.3 self-tuning--Activation

Self-tuning can be activated under the following conditions:

- Automatic operating (closed loop)
- PID control algorithm (*PI*, *r5P*, or *Prog*)

In the following circumstances, self-tuning is halted or overridden:

1. Tuning is halted when the controller is switched over from automatic to manual. It automatically begins afresh when switched back to closed-loop (if not switched off in between times).
2. In a power outage the process is interrupted. If automatic tuning is configured to take place on application of mains power, tuning re-starts when the power supply returns.
3. If the programmer/controller is executing a program, tuning cannot be activated during a ramp. The program must be reset beforehand (*idLE*) or halted (*HoLD*).
4. If the instrument is configured as a PID controller with ramped setpoint (*r5P*), the tuning procedure overrides the start-up ramp.
5. Self-tuning can be activated with two different parameters, the tuning setpoint can be adjusted for about one minute after the start.

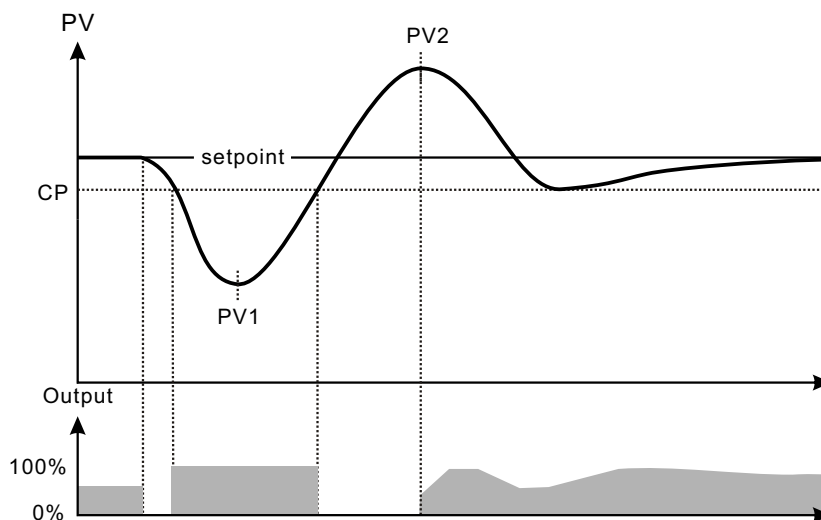

Self-tuning from setpoint--heating process

10. Configuration

Correct Configuration shall be done to parameters such as input, output and other functions before the AL808 instrument is put into operation, and only configured instruments can be put into operation.

Set the configuration password to 808 (Loc). When the instrument is in the PV/SV display status, depress the PAR button and ▲ button for 3 seconds (first press the PAR button without release, and then press the ▲ button for 3 seconds), the instrument will enter the software configuration menu. The upper display will display the first parameter, and the lower display will display the value of the parameter. At this time, use button ▲ or ▼ to modify the value of the parameter. After modification, press the PAR key, and the instrument will display the next parameter and its mnemonic, at the same time, the modified data will be saved in the memory.

If the last parameter is displayed or there is no pushbutton pressing operation within 16 seconds, the instrument will return back to the PV/SV display status.

After configuration, set the configuration password parameter (Loc) to data other than 808, so as to protect the parameter from being inadvertent modification by personnel on site.

Parameter list

S.N.	Mnemonic	Parameter	Adjustable range	Comments
1	SP H	Setpoint high limit	Measurement range	always > SP L
2	SP L	Setpoint low limit	Measurement range	always < SP H
3	HP L	Max output power	0.0 to 100.0	
4	SnbP	Sensor break power	0.0 to 100.0	
5	OFFSt	Input/calibration offset	-19.99 to 99.99	
6	[--F	°C/°F unit selection	C Centigrade F Fahrenheit	Affects all temperature dependent parameters
7	Sn	Input signal	Jtc Ktc Etc Rtc Stc Btc Ttc Pt100 Pt100(0.1 prec) Cu50 Cu50(0.1 prec) Lin Lin(0.1 prec) PrE PrE	J thermocouple K thermocouple E thermocouple R thermocouple S thermocouple B thermocouple T thermocouple Pt100 Pt100(0.1 prec) Cu50 Cu50(0.1 prec) Linear input Linear input (0.1 prec) Linear resistance signal Linear resistance signal (0.1 prec)
8	Raddr	Comms address	00 to 99	
9	bRud	Comms baud rate	600 1200 2400 4800 9600 19.2	
10	ctrL	Control algorithm	on,off P, d rSP Prog	On/Off Proportional integral derivative PID with ramp to SP PID programmer/controller
11	SPrr	Ramp to setpoint	0.01 to 99.99	Only appears if [ctrL = rSP (°C/min)

S.N.	Mnemonic	Parameter	Adjustable range	Comments
12	<i>OP1</i>	Output 1	<i>tP</i> 0-20 4-20	Time-proportioned 0~20mA output 4~20mA output
13	<i>OP2</i>	Output 2	<i>OFF</i> <i>FRn</i> <i>oil</i> <i>H2O</i> <i>0.05</i> <i>ALD2</i> <i>on</i>	Off Fan cooling, linear Oil cooling, linear Water cooling, non-linear Compressor refrigeration 2nd alarm output On
14	<i>ALD1</i>	Alarm 1	<i>H, RL</i> <i>LoRL</i> <i>HdR</i> <i>LdR</i> <i>dRo</i> <i>ndRo</i> <i>Pout</i>	Full-scale high alarm Full-scale low alarm High-deviation alarm low-deviation alarm outside deviation band alarm Inside deviation band alarm Alarm when program halt
15	<i>ALD2</i>	Alarm 2 Appears only if <i>OP2</i> is configured as <i>ALD2</i>		
16	<i>A--M</i>	Auto/manual enable	<i>Ruto</i> <i>HRnd</i>	Changeover locked out Changerover possible
17	<i>cJc</i>	CJC reference selection	<i>int</i> 0. 45. 50.	Internal reference 0°C external reference 45°C external reference 50°C external reference
18	<i>Pbd</i>	Proportional band display	<i>L-F</i> <i>L, n</i> <i>Pct</i>	°C or °F Linear input unit Percentage
19	<i>PH-L</i>	Proportional band scale factor	10 to 1500 °C	Appears only if <i>Pbd</i> is configured as <i>Pct</i>
20	<i>Act</i>	Control action	<i>rEu</i> <i>d, r</i>	Automatic Reverse Direct
21	<i>H, L</i>	Measurement range upper limit(sensor break)	-1999 to 9999	Appers only when input are linear input (<i>Sn</i> is configured as <i>L, n</i> or <i>.L, n, PrE</i> or <i>.PrE</i>)
22	<i>LoL</i>	Measurement range lower limit(sensor break)	-1999 to 9999	
23	<i>F, L</i>	Input filter	0.01 to 99.99	
24	<i>Proc</i>	Process scaling (straight line equation)	<i>P1</i> <i>P2</i>	

Pre-Configuration, Parameter Setting

A large number of parameters are installation-dependent, and as such only need setting once before commissioning. This setting should take place before connecting the instrument to the plant.

Warning: Never configure the instrument while it is controlling a process.

ON/OFF Controller:

This is limited to relay and triac outputs. It is most suitable for cases where high accuracy is not required. It is used in inexpensive applications and often as over or under temperature alarm interlock.

If the instrument is configured as an ON/OFF controller, the output hysteresis is set using the proportional band (*PrbP*).

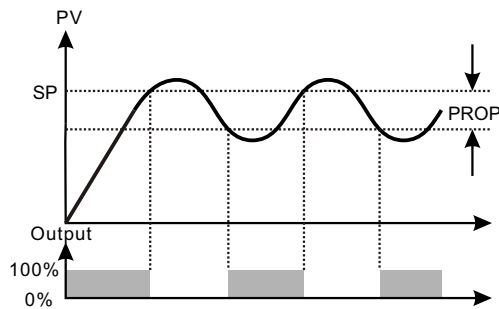

On/Off Control Operation

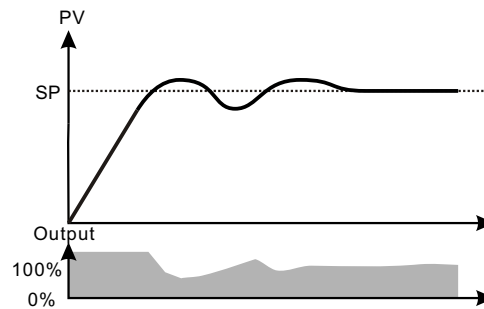

PID Control Operation

PID Controller: Proportional plus Integral plus Derivative control is typically used for high accuracy applications. The output type can be DC voltage or current as well as any time proportioning device, such as a relay, triac or logic output. The terms may have to be adjusted during commissioning. Periodic tuning may be necessary if the dynamics of the process change significantly over time.

By turning off I and D as appropriate it is possible to configure these controllers as PD, PI, or P only. P or PD control is typically used for situations where straight line control is required but offsets during steady-state are tolerable. PI control gives offset free steady-state control and PID gives tight control with little or no overshoot when well tuned.

OP1, OP2

Time proportioning

This applies to relay, logic or triac outputs (i.e. ON/OFF devices) and PID control. The percentage 'on' time of the device over a period is proportional to the power demand of the PID. Appropriate cycle times can be selected to suit the type of output device and the process response time.

Analogue output

Where continuously variable control is required. DC volts or current are available. 4 to 20 mA is a standard output. Other standard outputs are 0 to 5V, 0 to 10V, 1 to 5V, 0 to 20mA.

When setting OP1 (output 1) and OP2 (output 2), pay attention to their matching with the selected output modules. If the output module is relay, logic or SCR, OP1 would be set to EP output. If the output module is current output, OP1 would be set to 4~20 mA or 4~20 mA.

Act

A reverse acting controller (parameter rEu) will reduce its output demand as the process variable increases. rEu should be selected for temperature control loops with the heat output.

A direct acting controller (parameter dir) will increase its output demand as its process variable increases. dir should be selected for temperature control loops with the cool output.

Pbd, PH-L

Proportional band: With the Pbd parameter, one can select whether the proportional band should be displayed in units or in percentage. If the percentage setting is chosen, the range is determined using the PH-L parameter, to which the percentage data refers. The value should be equal to the measurement range of the instrument.

AL01, AL02

Alarm—Two alarms outputs may be installed in the controller. Six different types of alarm can be set up with these alarm outputs by configuration:

- Full-scale high alarm(H, RL) Alarm operates above an absolute level.
- Full-scale low alarm(LoRL) Alarm operates below an absolute level.
- High-deviation alarm(HdR) Alarm operates above a defined band above the control level.
- Low-deviation alarm(LdR) Alarm operates below a defined band below the control level.
- Outside deviation band alarm(dR_o) Alarm operates outside a defined band around the control level.
- Inside deviation band alarm(*n*dR_o) Alarm operates inside a defined band around the control level.

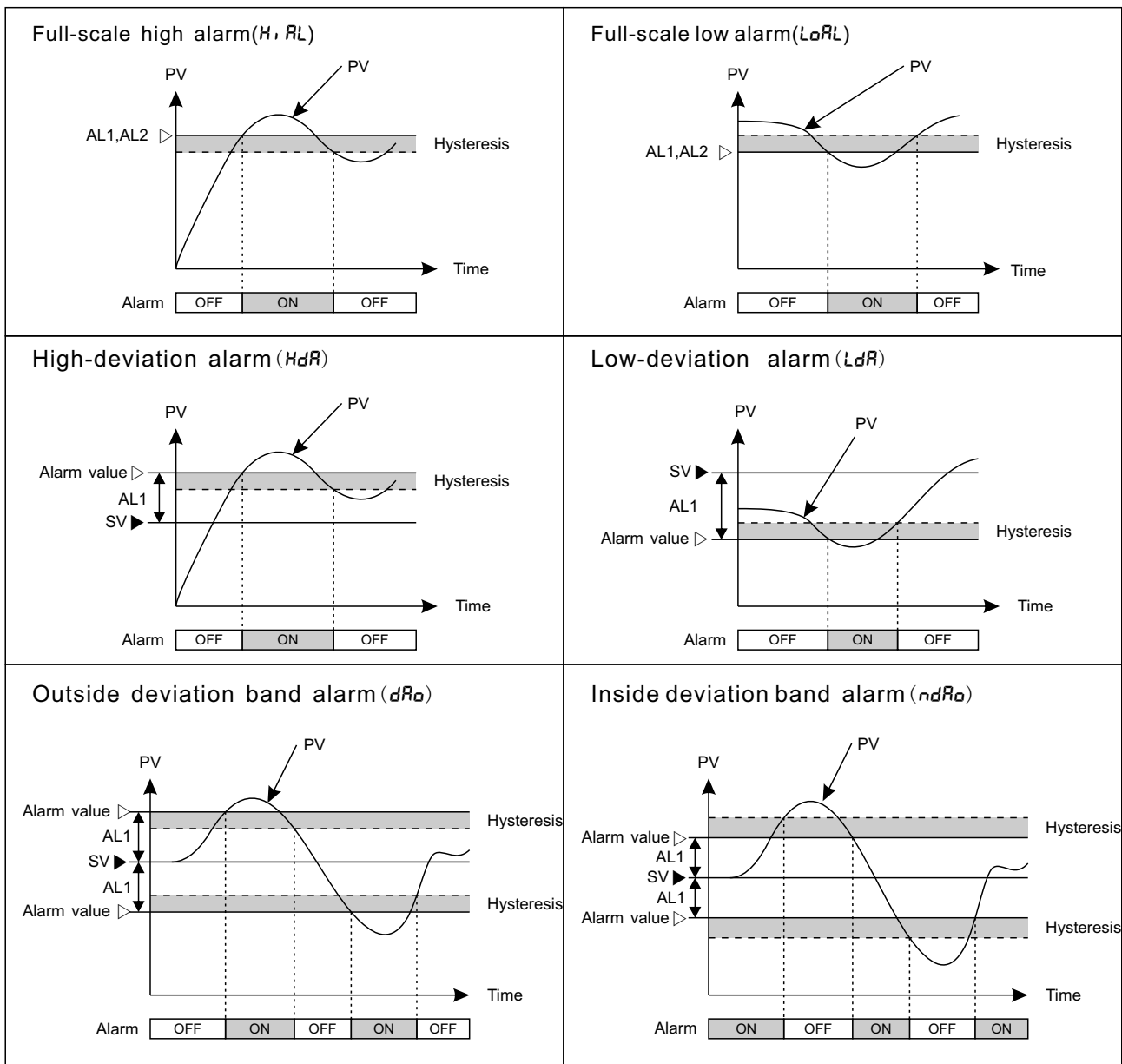

11. Linear Input

To measure physical parameters such as pressure, humidity, tension, weight, voltage and current, must transform these physical quantities into analog voltage signals, and set the AL808 input signal S_n to LIN or LIN.

The input to the controller must be between -10mV to 50mV, Voltage signal which **exceed** this range must be attenuated with an appropriately sized input adapter. Current signals are converted to the -10 to 50mV range with a shunt input adapter.

e.g.	Input	Adapter
	4 to 20 mA	Ri=2.5Ω
	0 to 10 V	Ri=1k/200kΩ

11.1 Setup and Configuration

- Set the sensor selection parameter S_n to LIN or LIN;
- Set H, L to the point desired to be the sensor overrange point or the sensor upper break point (in display units). If the input signal causes the display value to exceed this threshold, the controller enters the sensor break condition.
- Set L, L to the point desired to be the sensor underrange point or the sensor lower break point (in display units). If the input signal cause the display value fall below this threshold, the controller enters the sensor break condition.
- Set F, L to appropriate value, the bigger is the F, L , the more stable it is, but the response will be slower.

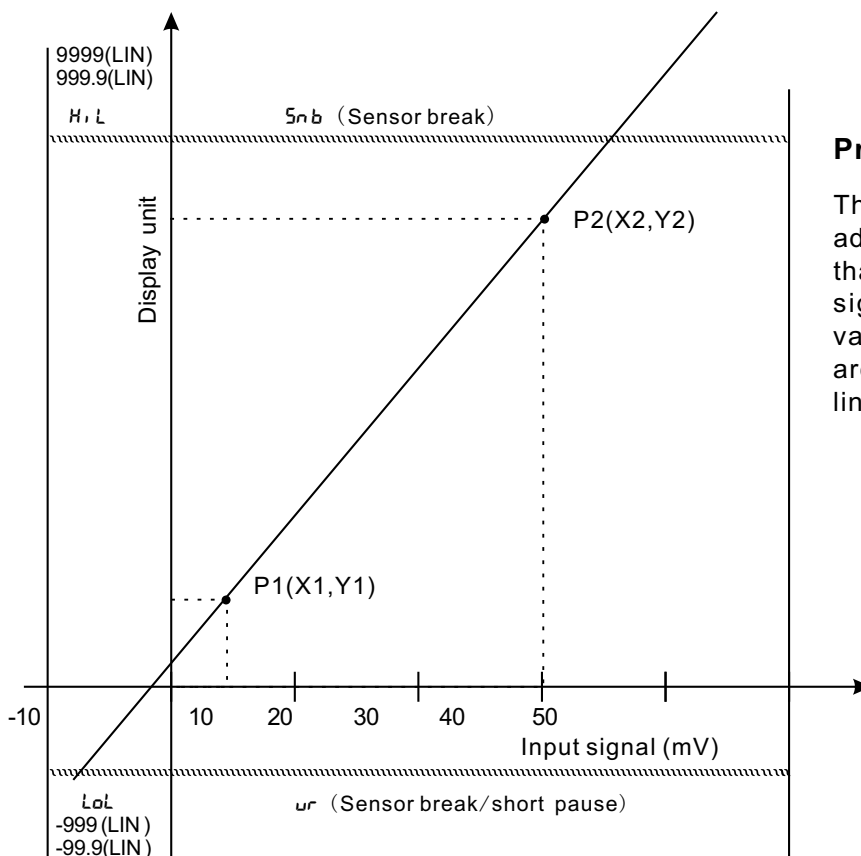

Principle:

The scaling procedure entails adjusting 2 setpoint, P1 and P2, that link know value input signals to specific display values. These 2 scaling value are used to define a straight line and are not interactive.

11.2 Scaling Procedure

The following two examples are used to describe the checking and programming procedures: input 4~20 mA, so that the corresponding display of the AL808 is 50~2500, and the check steps are as follows:

Connect a resistor of 2.5Ω at the input terminal, so that the input signal is within the range of 0 to 50mV.

Connect the controller to some form signal generator which can reproduce the sensor output, or to the sensor itself if the sensor can be induced to supply various signal levels.

P1:

STEP	BUTTON OPERATION	DISPLAY
1	Connect source (form signal generator or sensor to input terminals before proceeding. Apply a signal equal to 4mA for the first setup point(P1)	
2	Depress PAR pushbutton until <i>Proc</i> appears in the upper display	<i>Proc</i> ----
3	Depress ▲ pushbutton, P1 appears in lower display	<i>Proc</i> P1
4	Depress PAR again: the number in the lower display will be the value (after adjustment) assigned to the injected input signal	P1 150
5	Depress ▲ or ▼ pushbutton to adjust the number in the lower display until it corresponds to the value represented by the injected signal (4mA)	P1 50
6	Depress PAR pushbutton:	50 no
7	Press ▲ pushbutton to affirm:	50 YES
8	Depress PAR pushbutton, P1 appears in the upper and lower display at the same time	P1 P1
9	5 seconds later, the scaling of the 1st setup point is completed	<i>Proc</i> ----

P2:

STEP	BUTTON OPERATION	DISPLAY
1	Apply a signal equal to 20mA for the second setup point(P2)	
2	Depress PAR pushbutton until <i>Proc</i> appears in the upper display	<i>Proc</i> ----
3	Depress ▲ pushbutton until P2 appears in lower display	<i>Proc</i> P2
4	Depress PAR again: the number in the lower display will be the value (after adjustment) assigned to the injected input signal	P2 1500
5	Depress ▲ or ▼ pushbutton to adjust the number in the lower display until it corresponds to the value represented by the injected signal (20mA)	P2 2500
6	Depress PAR pushbutton:	2500 no
7	Press ▲ pushbutton to affirm:	2500 YES
8	Depress PAR pushbutton, P2 appears in the upper and lower display at the same time	P2 P2
9	5 seconds later, the scaling of the 2nd setup point is completed	<i>Proc</i> ----

12. Programmer/Controller

12.1 General Description

Model 808 and 809 with special function contain an in-built setpoint generator in addition to the controller function. This setpoint generator can produce a temperature/time profile with multi-segments. When the program is running, the current setpoint from the setpoint generator is fed to the control algorithm. The current setpoint is continuously shown on the lower display.

The multi-segments are defined in the order: Ramp 1, Dwell period 1, Ramp 2, Dwell period 2 and so on, and are executed in succession. According to users' requirements, instruments with 4, 8, 16 or 32-segments can be chosen.

A **ramp** consists of a slope(linear gradient) and a target setpoint. The control setpoint increases or decreases at a linear ramp rate from the actual measured value until a specified target setpoint is reached . The relative positions of the actual measured value and the target setpoint determine whether the slope of the ramp is positive or negative. Unit: °C/min.

In a **Dwell period**, the target setpoint, which has been attained, remains unchanged for a fixed period. When the program is running, these parameter display the time remaining in the active dwell period. If the parameter equals zero, the dwell period is skipped.

12.2 Program Parameter

First, Ctrl must be configured as *Prog*. When the instrument is in the PV/SV display status, Depress PAR key first, and then press the \downarrow key(about 3 seconds) until the first program parameter appears in the upper display. The value associated with this parameter is shown in the lower display. At this time, you can use the 'lower' and 'raise' pushbutton to modify the parameter's value. Then, press the PAR key, the next parameter appears. At the same time, the modification has been saved in the memory.

If no buttons are pressed within 16 seconds, the display returns to the base condition.

Program Parameter List These parameters appear only if Ctrl is configured as *Prog*

S. N.	Mnemonic	Parameter	Adjustable range	Comments
1	Lc	Loop counter	1 to 200, <i>cont</i> (continuous)	
2	r1	1st ramp rate	<i>End;5tEP</i> , 0.01 to 99.99 units/min	
3	L1	1st target setpoint	<i>5PL</i> to <i>5PH</i>	
4	d1	1st dwell time	0 to 9999 minutes	
5	r2	2st ramp rate	<i>End;5tEP</i> , 0.01 to 99.99 units/min	
6	L2	2st target setpoint	<i>5PL</i> to <i>5PH</i>	
7	d2	2st dwell time	0 to 9999 minutes	
...
8	Hb	Holdback(band)	1 to 9999°C	Only appears if Ctrl is configured as <i>Prog</i> or <i>rSP</i>

Parameter Description

$r1$: If $r1$ is configured as End , the program will be ended when the program runs to the slope;

If $r1$ is configured as $StEP$, the program will skip this slope, and directly goto the next dwell period.

$L1$: The target value to which the setpoint ramps when the programmer has been placed into run . Note that the adjustment range of this level is bound by the setpoint limit parameter $SP H$ and $SP L$.

$d1$: The value of this parameter indicates the time remaining in the dwell segment if the value is viewed while the program is currently in this particular dwell segment. The segment is skipped if $d1$ is set to zero minutes.

$L2$: This parameter determines the number of iterations of the program. Note that when a program is running, the value indicates will select the number of iterations remaining including the current iteration before the programmer reverts to $Idle$.

Hb : For detail, see the next page "Programmer States".

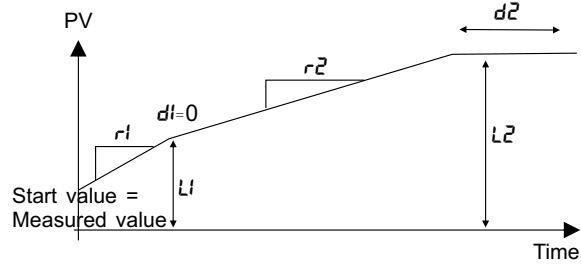
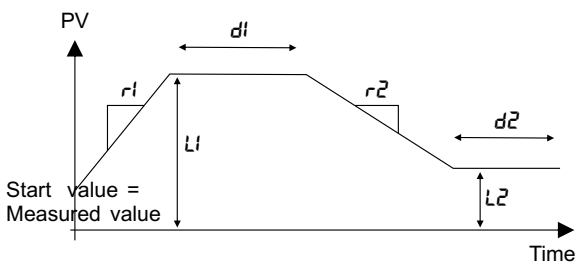
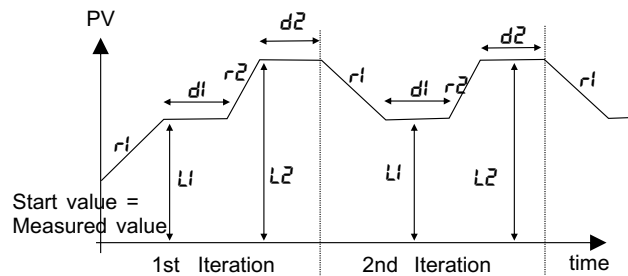
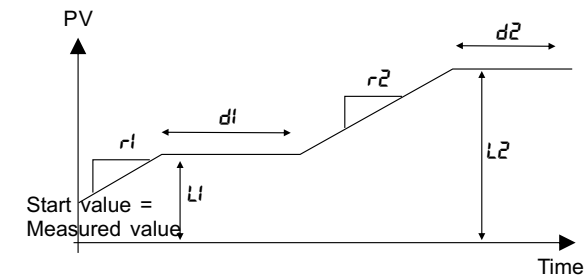

12.3 Programmer States

The programmer/controller can be placed in three different states: *idle*, *run* and *hold*. An additional, non-selectable state is holdback(*Hb*).

idle: If the programmer/controller has been placed in the *idle* state, it operates as a simple controller with the setpoint shown on the lower display.

run: In the *run* state, the program has been started and is executing. When started from the *idle* state, the program is always launched from the beginning, at the end of the program it returns to *idle*. The current running segment is displayed together with the configured unit, by depressing the PAR button once. A program which is running may be reset by selecting *idle*.

hold: A program which is running (*run*) is halted by selecting *hold*. The program generator stops the program on the current setpoint, and the time-base is halted. From the *hold* state, the program can be continued (*run*) or reset (*idle*).

The holdback state (*Hb*) is a special case of *hold*. It is activated of its own accord by the programmer/controller and cannot be selected by the user. The *Hb* parameter allows the user to set the difference tolerated between the current setpoint and the actual value while the program is running. If this difference is exceeded, the program generator halts itself in order for the process value to catch up with the program setpoint. In a dwell period the time-base is halted. If the difference between setpoint and actual value is again smaller than *Hb*, the program is continued.

To switch off holdback, set the parameter to a very high value.

12.4 Program Control Methods

The state of the programmer can be modified in three ways. All of the three have the same priority and the last action from any of them is acted upon:

1. Via the **front panel pushbuttons**, by choosing the parameter *Prog* and selecting the parameter value (*idle*, *run* or *hold*). Note that the rear terminals 12 & 13 must be bridged during this time.

2. Via the **rear terminal 12 & 13** as shown in the terminal layout. When the instrument is in *run* or *hold* state, short circuit terminals 12 and 13. If terminals 12 and 13 are already in the short circuit status, first disconnect them before short circuiting them again, so that the instrument enters the running status (*run*).

When the instrument is in the running status, disconnect terminals 12 and 13, so that the instrument enters the suspension status (*hold*).

3. Via the **digital communications** board, by modifying the status word, see special **Communications Handbook** for ALTEC AL808 series controller. The Communication Handbook and communication test software can be downloaded from our website (<http://www.china-altec.com>).

12.5 Annunciators

The LED indicator **Ramp** indicates the current state of the programmer/controller:

LED off →IDLE

LED on →RUN

LED flashing →Hold or Holdback

Note that the LED indicator Ramp will be on at the slope when Ctrl is configured as $r\ SP$.

Display of running program segments:

When the instrument is in the run, Hb or HoLd status, press the PAR key, the lower row of monitors will display codes $r1, d1, r2, d2\dots Hb$ for the current running section and the code of the unit.

Display of remaining time:

When the instrument is running in the platform sections ($d1$ or $d2$), the value displayed under the parameter code of the section is the remaining time of the section's running instead of the total running time of the section.

Display of set value:

When the instrument is in run, HoLd or Hb status, the values displayed in the lower row of monitors are the set values (SV) under implementation instead of basic set values (SP), while the values displayed under the SP parameter code are basic set values (SP).

When the instrument is in the stop status (idle), the lower row of monitors will display the basic set values (SP).

12.6 Changing Program Parameter

In the *run* state, the parameters specific to the program, $Lc, r1, L1, d1, r2, L2$ and $d2$, can't be modified. A modification is possible to the other parameter, the modification is permanent.

In the *IdLE* state, all the parameters can be modified, the modification is permanent.

In the *HoLd* state, the parameters specific to the program, $Lc, r1, L1, d1, r2, L2$ and $d2$ can be modified, the modification is, however, not permanent and is valid only for the current iteration of the program. A modification is possible to the other parameter, the modification is permanent.

12.7 Program Recovery Following Loss of Power

All the instrument parameter are stored in non-volatile memory. When power is lost, the current point in the program is also stored in the memory. When power is restored, the programmer/controller resumes the program in the appropriate segment at the point reached at the moment of interruption, as soon as the process value re-enters the holdback band.

13. Supplements Relating to AL809 Valve Positioning Controller

The AL809 valve controller employs two lines of outputs to directly control forward and reverse rotation of control valve's motors, adjust the valve position, so as to control physical quantities such as temperature and pressure. The employment of AL809 valve controller can save motor implementation organization. Therefore, it is more stable and more precise than regular method, with lower cost.

The dimensions, technical data, operation etc. are equivalent to the 808 controller series and can be take from appropriate chapters of this manual.

13.1 Additional Parameter for Valve Positioning Controller

You can find general parameter for AL809 on page 10, parameter list. In addition, the following control parameters can be accessed and modified. No parameter or code related to OP1 or OP2 is displayed in the AL808 controller, and proportional integration control is employed for AL809, without needing differentiation parameters. AL809 can employ PI auto-tuning.

During normal display, press the A/M key to view the valve position.

Mnemonic	Parameter	Adjustable range	Function
<i>tt</i>	Motor travel time	0.1 to 240s	Motor travel time
<i>b15h</i>	Motor delay time (mechanical backlash)	0.0 to 20% of motion range	Mechanical backlash
<i>ct</i>	Cycle time	0.1 to 240s	Output cycle frequency
<i>int</i>	Motor inertia time	0.000 to 1.0s	Inertia (Motor inertia time)
<i>ctrl</i>	Control algorithm	<i>on.off</i> <i>uRLu</i> <i>r5P</i> <i>Prog</i>	On/off Valve positioner with PID Valve positioner with ramp to SP SP programming

Adjustment note: Motor travel time, -use the value form the manufacturers' data sheet or measure the travel time using manual mode. The cycle time must be very much shorter than the motor travel time(<5%).

13.2 Valve Positioning Controller Output(motor open/close)

Relay, SCR or logic can be chosen for output signals.

More (open), OUT1: Terminal 7 & 8

Less (close), OUT2: Terminal 5 & 6

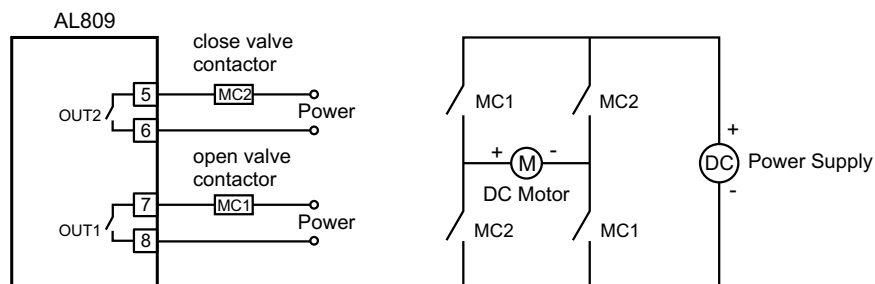

Technical Data

Accuracy	±0.2%+1 digital
Sample rate	125ms
Input	Thermocouple: J, K, E, R, S, T, and B RTD: Pt100 and Cu50 Linear input: 0~20 mA, 4~20 mA, -10~50 mV, and 0~10 V
Output	Relay(max. 250 VAC, 3A) Logicl, 20 V/10 mA Triac DC output: 0~10 mA, 4~20 mA, 0~20 mA, or 0~5 V, 1~5 V, and 0~10 V
Alarm	Relay(max. 250 VAC, 3 A) Modes: upper and lower limit alarm, and deviation alarm
program	4, 8, 16, 32-segments Cycle: 1~200 times or continuous
Control algorithm	On/off PID and PID self-tuning
Communications	RS-422, RS-485, RS-232
Power supply	Voltage range: 85~264 VAC; 45/60 Hz
Environment	Temperature: 0~50°C, Humidity: ≤85%

Measurement Range

Code	Input	Measurement Range(C°)	Measurement Range(°F)
Jtc	J thermocouple	-135 to 1000	-211 to 1832
Ktc	K thermocouple	-255 to 1395	-427 to 2543
Enc	E thermocouple	-99 to 749	-427 to 1380
rtc	R thermocouple	-50 to 1767	-58 to 3213
Stc	S thermocouple	-50 to 1767	-58 to 3213
btc	B thermocouple	-50 to 1967	-58 to 3313
ttc	T thermocouple	-260 to 400	-436 to 752
rtd	Pt100	-100 to 1000	-100 to 1000
.rtd	Pt100	-99.9 to 999.9	-99.9 to 999.9
cu	Cu50	-50 to 150	-50 to 150
.cu	Cu50 (1/10' prec)	-49.99 to 149.9	-49.9 to 149.9
lin	Linear input	-1999 to 9999	-1999 to 9999
.lin	Linear input (1/10' prec)	-199.9 to 999.9	-199.9 to 999.9
PRE	Linear resistance	-1999 to 9999	-1999 to 9999
.PRE	Linear resistance	-199.9 to 999.9	-199.9 to 999.9